

# AVIATOR

## 5t, 10t, 20t, 30t & 40t Hi-Technology Portable Aircraft Weigh Pads

**AVIATOR** is a durable hi-tech precision scale designed to excel in demanding commercial and military aviation environments. Constructed with high quality state of the art materials, ensuring reliable and accurate long-lasting performance in extreme conditions.

What sets AVIATOR apart is its exceptional accuracy, equipped with advanced weight sensors, providing precise weight and balance measurements critical for optimising flight safety, fuel efficiency, and load management.

User-friendly and portable, featuring an intuitive interface plug-and-play functionality for quick deployment. Compact, lightweight design allows for easy transport and storage, making it ideal for both large airports, MRO facilities and remote airstrips.

### Features:

- 7075-T651 aviation-grade aluminium alloy scale body (mild steel ramp + back stop).
- 40mm LCD display easy to read instant display.
- Connect multiple weigh pads to 1 touch screen wired/wireless controller.



AVIATOR Standard  
5T, 10T, 20T & 30T



AVIATOR Low Profile  
10T, 20T, 30T & 40T



## Wired/Wireless Aircraft M6+ Controller Features:

- Multipoint LCD Smart Touch Screen
- Up to 16 channel input
- 10 working hours (20 hours with screensaver)
- Multiple users
- Operating Temperature 0°C to +40°C
- Wireless range of up to 30m line of sight
- Built in tally roll printer
- Export data via USB2.0



Aircraft M6+ Touch Screen Controller

## Weighing Report

2022-01-13 10:18

Serial No. : 00007

Model : HL600

Sorties : 1003

Total Weight : 9990kg

Nose Wheel : 0kg

Rear Wheel Left 1 : 0kg

Rear Wheel Left 2 : 0kg

Rear Wheel Left Total : 0kg

Rear Wheel Right 1 : 9990kg

Rear Wheel Right 2 : 0kg

Rear Wheel Right Total : 9990kg

Center of Gravity (Before correction) : 18.395m

Relative Center of Gravity (Before correction) : 55.98%

Printout sample

## Software sample:

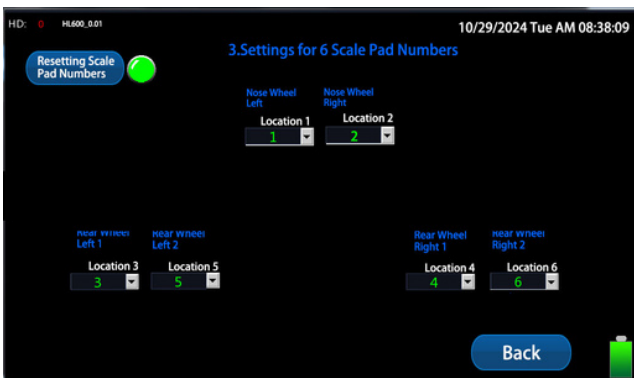

## Towable Transport and Storage Cart with Weatherproof Cover:



# AVIATOR Standard 5t, 10t, 20t & 30t



## TECHNICAL DATA

Model	AVIATOR-5t	AVIATOR-10t	AVIATOR-20t	AVIATOR-30t
Overall Weighing Area Dimensions (mm)	610(L) x 305(W)	610(L) x 305(W)	610(L) x 534(W)	610(L) x 534(W)
Platform Dimensions (mm)	620(L) x 391(W) x 58(H)	620(L) x 391(W) x 58(H)	620(L) x 620(W) x 58(H)	620(L) x 620(W) x 58(H)
Ramp Dimensions (mm)	590(L) x 407(W)	590(L) x 407(W)	590(L) x 636(W)	590(L) x 636(W)
Approx. Pad Weight	19.5kg	21kg	33.7kg	43.2kg
Approx. Ramp Weight	14.3kg	14.3kg	23.7kg	23.7kg
Approx. Stopper Weight	6.82kg	6.82kg	10.83kg	10.83kg
Max Capacity	5,000kg	10,000kg	20,000kg	30,000 kg
Division	1 kg	5kg	5kg	10kg
Accuracy	±0.1%			
Load Cell	6 pcs	6 pcs	8 pcs	12 pcs
Working Temperature	-10°C to +50°C			
Working Hours Approx.	120 hrs			
Connection	20m Cable or RFID Wireless Controller			
Overall performance may be influenced by the graduation size, capacity, and calibration parameters.				

## Outline dimensions (mm)

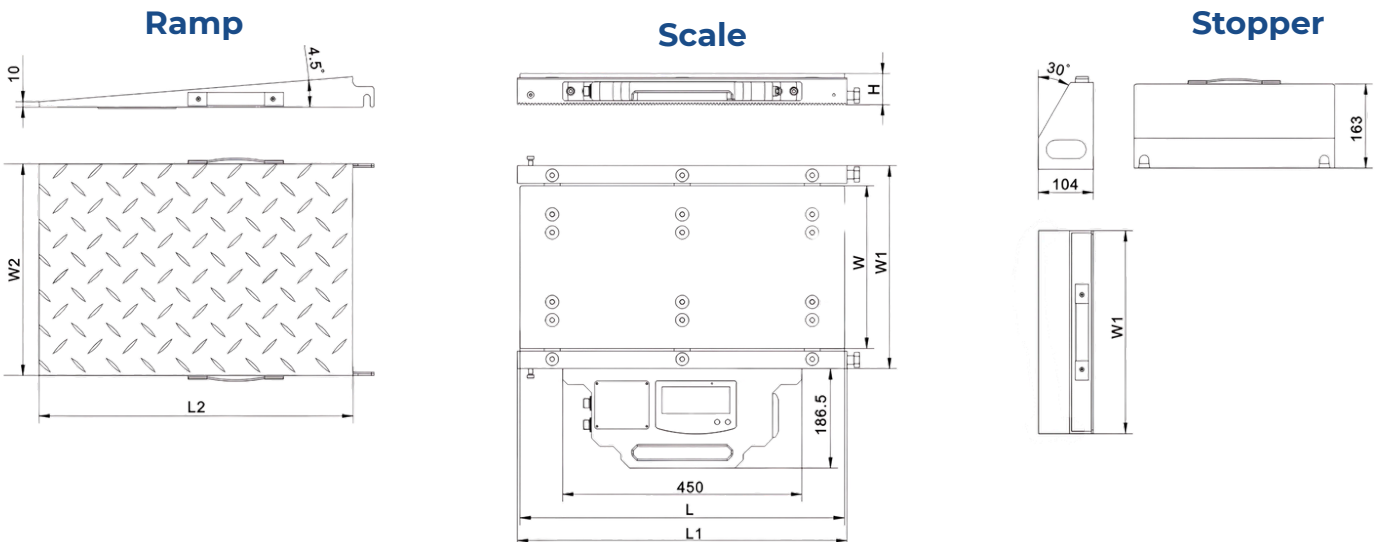

# AVIATOR Low Profile 10t, 20t, 30t & 40t

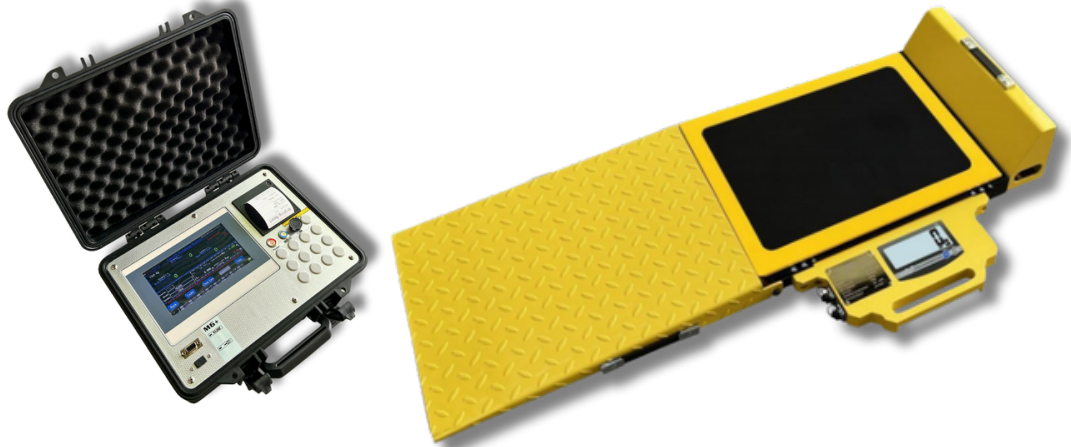

## TECHNICAL DATA

Model	AVIATOR-LP10t	AVIATOR-LP20t	AVIATOR-LP30t	AVIATOR-LP40t
Overall Weighing Area Dimensions (mm)	381(L) x 381(W)	570(L) x 381(W)	762(L) x 610(W)	762(L) x 610(W)
Platform Dimensions (mm)	406(L) x 406(W) x 43(H)	595(L) x 406(W) x 50(H)	788(L) x 635(W) x 58(H)	788(L) x 635(W) x 58(H)
Ramp Dimensions (mm)	430(L) x 422(W)	520(L) x 422(W)	590(L) x 651(W)	590(L) x 651(W)
Approx. Pad Weight	18.5kg	24.5kg	45kg	52kg
Approx. Ramp Weight	10.54kg	10.54kg	24.8kg	24.8kg
Approx. Stopper Weight	6.54kg	6.54kg	13.15kg	13.15kg
Max Capacity	10,000kg	20,000kg	30,000kg	40,000kg
Division	5kg	5kg	10kg	10kg
Accuracy	±0.1%			
Load Cell	6 pcs	8 pcs	12 pcs	16 pcs
Working Temperature	-10°C to +50°C			
Working Hours Approx.	120 hrs			
Connection	20m Cable or RFID Wireless Controller			
Overall performance may be influenced by the graduation size, capacity, and calibration parameters.				

## Outline dimensions (mm)

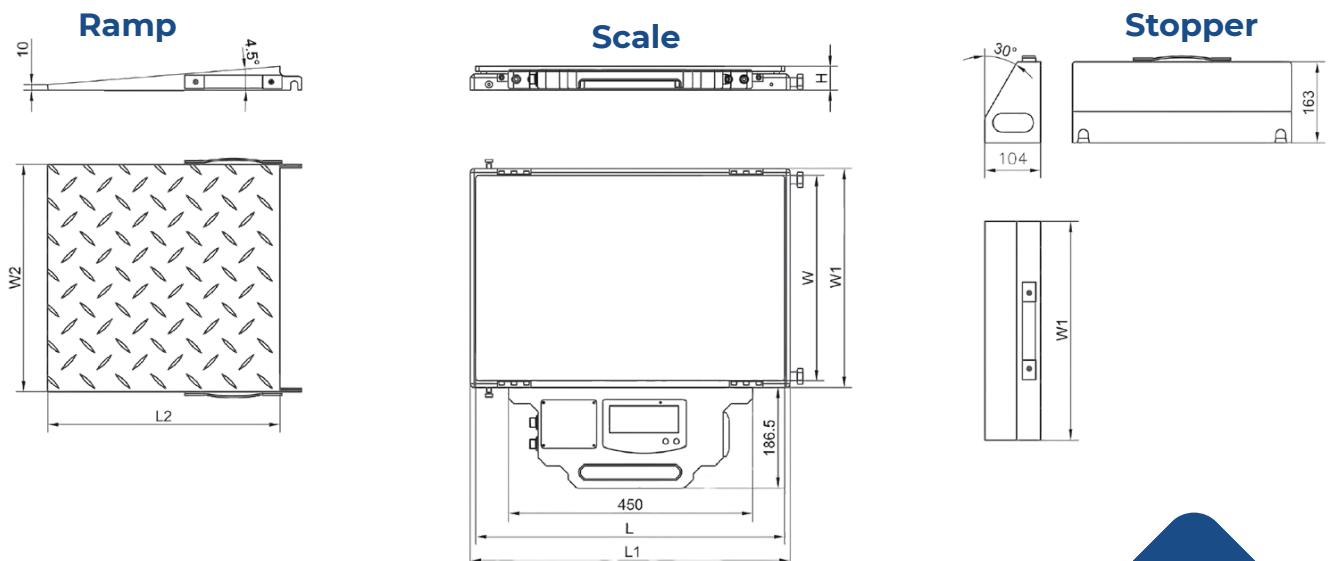

Global Sales & Service Agents

**TRAK BLAZE**  
MINING, RAIL, ROAD & AIRCRAFT WEIGHING SYSTEMS  
Over 95 Years of Innovation

T: +61 (0) 3 9318 9277 | info@trakblaze.com

www.trakblaze.com | 5 Mareno Road, Tullamarine, Victoria, Australia 3043

Follow us on